



SANYO Semiconductors

DATA SHEET

LV4900H — Bi-CMOS LSI Class-D Audio Power Amplifier BTL 10W×2ch

Overview

The LV4900H is a 10W per channel stereo digital power amplifier that takes analog inputs. The LV4900H uses unique SANYO-developed feedback technology to achieve excellent audio quality despite being a class D amplifier and can be used to implement high quality flat display panel (FDP) based systems.

Features

- Supports circuit designs that do not require output LC filters
- BTL output, class D amplifier system
- Unique SANYO-developed feedback technology achieves superb audio quality
- High-efficiency class D amplifier
- Soft muting function reduces impulse noise at power on/off
- Full complement of built-in protection circuits : overcurrent protection, thermal protection, and low power supply voltage protection circuits
- Built-in bootstrap diodes
- Internal oscillator frequencies : channel 1 = 325kHz, channel 2 = 300kHz

Functions

- 10W output (At $V_D = 12V$, $R_L = 8\Omega$, THD + N = 10%)
- 15W output (At $V_D = 12V$, $R_L = 4\Omega$, THD + N = 10%)
- Efficiency : 88% ($V_D = 12V$, $R_L = 8\Omega$, $f_{in} = 1kHz$, $P_O = 10W$)
- Low THD + N : 0.15% ($V_D = 12V$, $R_L = 8\Omega$, $f_{in} = 1kHz$, $P_O = 1W$, Filter : AES17)
- Noise : 100 μ Vrms (Filter : A-weight)

■ Any and all SANYO Semiconductor Co.,Ltd. products described or contained herein are, with regard to "standard application", intended for the use as general electronics equipment (home appliances, AV equipment, communication device, office equipment, industrial equipment etc.). The products mentioned herein shall not be intended for use for any "special application" (medical equipment whose purpose is to sustain life, aerospace instrument, nuclear control device, burning appliances, transportation machine, traffic signal system, safety equipment etc.) that shall require extremely high level of reliability and can directly threaten human lives in case of failure or malfunction of the product or may cause harm to human bodies, nor shall they grant any guarantee thereof. If you should intend to use our products for applications outside the standard applications of our customer who is considering such use and/or outside the scope of our intended standard applications, please consult with us prior to the intended use. If there is no consultation or inquiry before the intended use, our customer shall be solely responsible for the use.

■ Specifications of any and all SANYO Semiconductor Co.,Ltd. products described or contained herein stipulate the performance, characteristics, and functions of the described products in the independent state, and are not guarantees of the performance, characteristics, and functions of the described products as mounted in the customer's products or equipment. To verify symptoms and states that cannot be evaluated in an independent device, the customer should always evaluate and test devices mounted in the customer's products or equipment.

SANYO Semiconductor Co., Ltd.

TOKYO OFFICE Tokyo Bldg., 1-10, 1 Chome, Ueno, Taito-ku, TOKYO, 110-8534 JAPAN

LV4900H

Specifications

Maximum Ratings at $T_a = 25^\circ\text{C}$

Parameter	Symbol	Conditions	Ratings	Unit
Maximum supply voltage	VD	Externally applied voltage	15	V
Maximum output current	$I_{O \text{ peak}}$		3.75	A/ch
Allowable power dissipation	$P_d \text{ max}$	Independent package	886	mW
Operating temperature	T_{opr}		-25 to +75	$^\circ\text{C}$
Storage temperature	T_{stg}		-50 to +150	$^\circ\text{C}$

Operating Conditions at $T_a = 25^\circ\text{C}$

Parameter	Symbol	Conditions	Ratings			Unit
			min	typ	max	
Recommended supply voltage range	VD	Externally applied voltage	10	12	14	V
Recommended load resistance	R_L	Speaker load	4	8		Ω

Electrical Characteristics at $T_a = 25^\circ\text{C}$, $V_D = 12\text{V}$, $R_L = 8\Omega$, $L = 22\mu\text{H}$, $C = 0.33\mu\text{F}$

Parameter	Symbol	Conditions	Ratings			Unit
			min	typ	max	
Standby current	I_{st}	$\overline{\text{STBY}} = \text{L}$, $\overline{\text{MUTE}} = \text{L}$		13	25	μA
Muting current	I_{mute}	$\overline{\text{STBY}} = \text{H}$, $\overline{\text{MUTE}} = \text{L}$		13.5	20	mA
Quiescent current	I_{CCO}	$\overline{\text{STBY}} = \text{H}$, $\overline{\text{MUTE}} = \text{H}$		60	70	mA
Voltage gain	VG	$f_{in} = 1\text{kHz}$, $V_O = 0\text{dBm}$	27	29	31	dB
Output offset voltage	V_{offset}	$R_g = 0$	-150		150	mV
Total harmonic distortion	THD@1W	$P_O = 1\text{W}$, $f_{in} = 1\text{kHz}$, AES17		0.15	0.5	%
Maximum output	$P_{O1@10\%}$	THD+N = 10%, AES17	8	10		W
Channel separation	CH sep.	$R_g = 0$, $V_O = 0\text{dBm}$, DIN AUDIO	55	70		dB
Ripple rejection ratio	SVRR	$f_r = 100\text{Hz}$, $V_r = 0\text{dBm}$, $R_g = 0$, A-weight	50	65		dB
Noise	V_{NO}	$R_g = 0$, A-weight		100	300	μVrms
High-level input voltage	V_{IH}	STBY pin and MUTE pin	3			V
Low-level input voltage	V_{IL}	STBY pin and MUTE pin			1	V
Power supply voltage drop protection circuit upper limit value	UV_UPPER	VD pin voltage monitor		8.0		V
Power supply voltage drop protection circuit lower limit value	UV_LOWER	VD pin voltage monitor		7.0		V

Note : The values of these characteristics were measured in the SANYO test environment. The actual values in an end system will vary depending on the printed circuit board pattern, the external components actually used, and other factors.

Package Dimensions

unit : mm (typ)

3235A

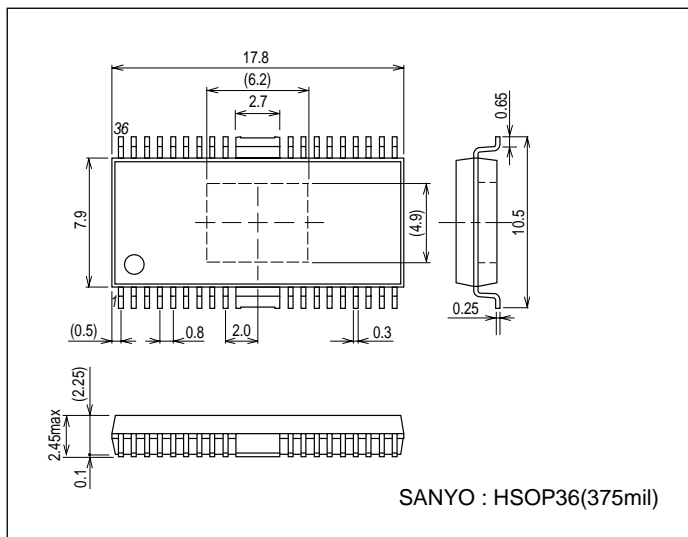

LV4900H

Block Diagram and Application Circuit Example 1 ($R_L = 8\Omega$)

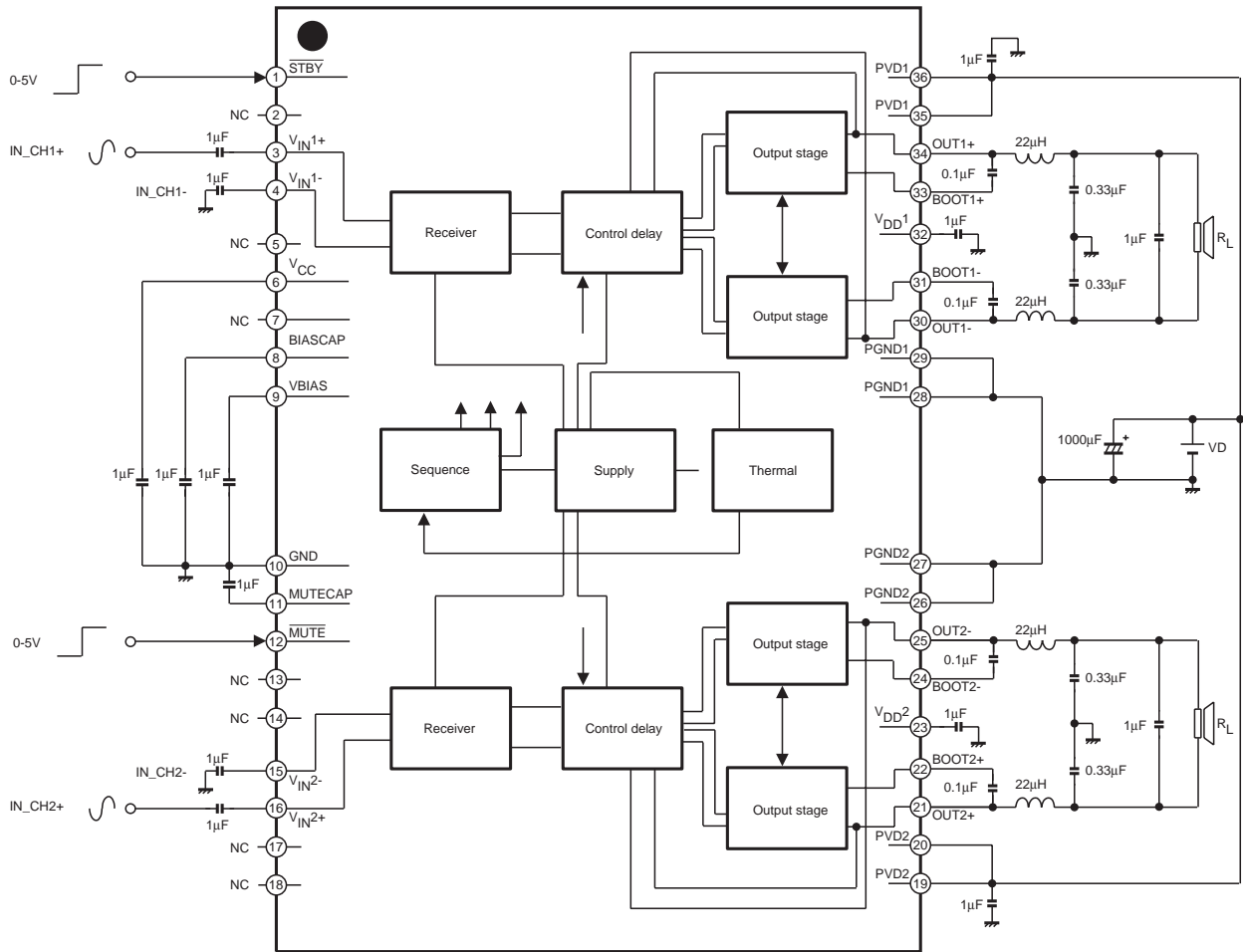

LV4900H

Application Circuit Example 2 ($R_L = 4\Omega$)

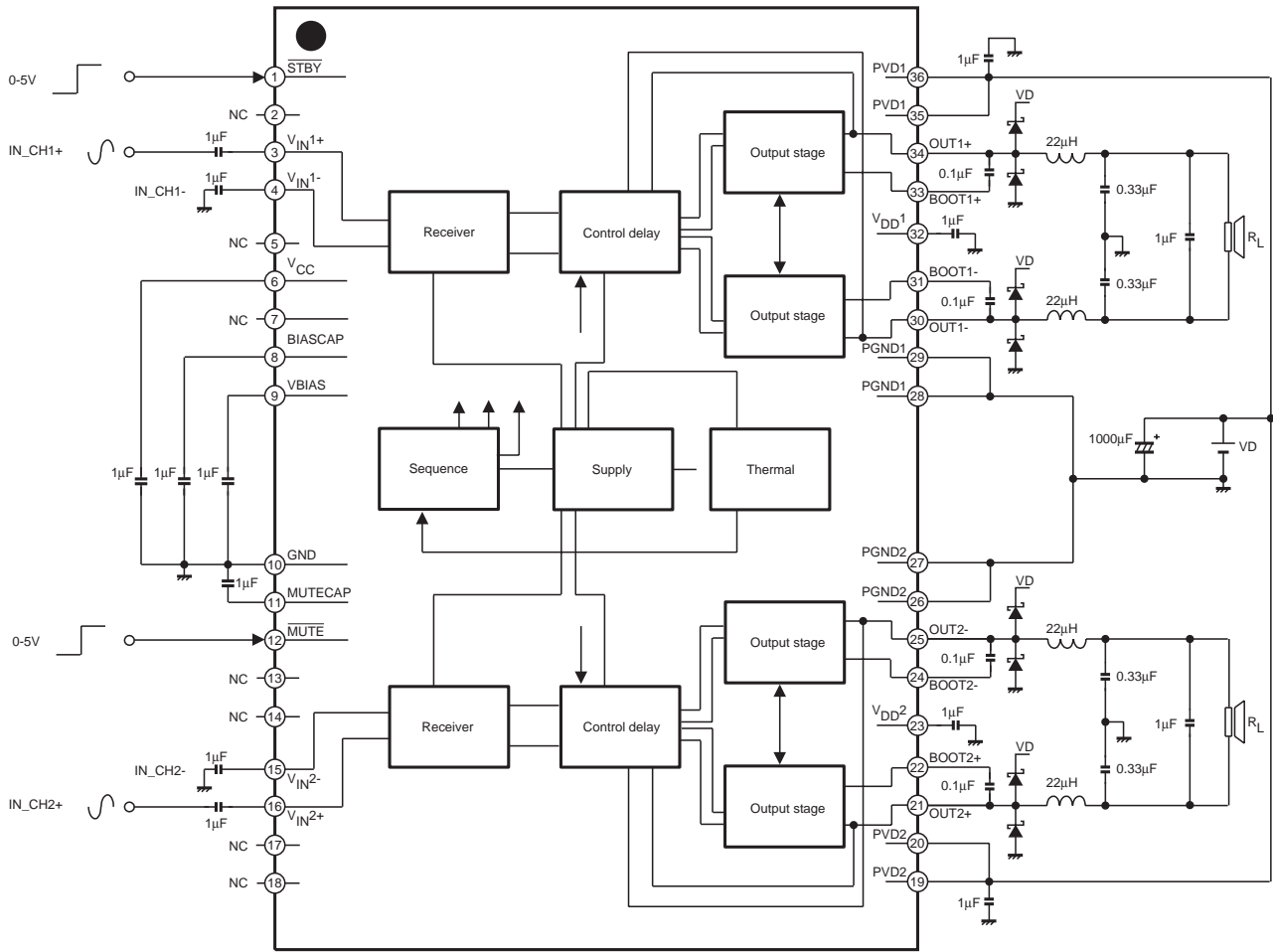

LV4900H

Pin Equivalent Circuit

Pin No.	Pin	I/O	Description	Equivalent Circuit
1	STBY	I	Standby mode control	
2	NC		No connection	
3	V _{IN1+}	I	Channel 1 noninverting input	
4	V _{IN1-}	I	Channel 1 inverting input	
5	NC		No connection	
6	V _{CC}	O	Internal power supply decoupling capacitor connection	
7	NC		No connection	
8	BIASCAP	O	Internal power supply decoupling capacitor connection	

Continued on next page.

LV4900H

Continued from preceding page.

Pin No.	Pin	I/O	Description	Equivalent Circuit
9	VBIAS	O	Internal power supply decoupling capacitor connection	
10	GND		Analog system ground	
11	MUTECAP	O	Muting system capacitor connection	
12	MUTE	I	Muting control	
13	NC		No connection	
14	NC		No connection	
15	V _{IN2-}	I	Channel 2 inverting input	
16	V _{IN2+}	I	Channel 2 noninverting input	
17	NC		No connection	
18	NC		No connection	
19	PVD2		Channel 2 power system power supply	
20	PVD2		Channel 2 power system power supply	

Continued on next page.

LV4900H

Continued from preceding page.

Pin No.	Pin	I/O	Description	Equivalent Circuit
21	OUT2+	O	Channel 2 high side output	
22	BOOT2+	I/O	Bootstrap I/O pin, channel 2 power supply high side	
23	V _{DD2}	O	Internal power supply decoupling capacitor connection	
24	BOOT2-	I/O	Bootstrap I/O pin, channel 2 power supply low side	
25	OUT2-	O	Channel 2 low side output	
26	PGND2		Channel 2 power system ground	
27	PGND2		Channel 2 power system ground	
28	PGND1		Channel 1 power system ground	
29	PGND1		Channel 1 power system ground	
30	OUT1-	O	Channel 1 low side output	
31	BOOT1-	I/O	Bootstrap I/O pin, channel 1 power supply low side	

Continued on next page.

LV4900H

Continued from preceding page.

Pin No.	Pin	I/O	Description	Equivalent Circuit
32	V _{DD1}	O	Internal power supply decoupling capacitor connection	
33	BOOT1+	I/O	Bootstrap I/O pin, channel 1 power supply high side	
34	OUT1+	O	Channel 1 high side output	
35	PVD1		Channel 1 power system power supply	
36	PVD1		Channel 1 power system power supply	

Note : Smoothing capacitors must be connected to each power supply pin.

Functional Descriptions

System Standby

The bias levels are turned on and off under control of the high/low state of the STBY pin. When the STBY pin is low, the bias levels will be turned off, and when that pin is high, the bias levels will be applied.

Mute Function

The mute function is provided mainly to mute the output so that impulse noise will not appear in the output when the power supply is being turned on.

(1) Output Muting

The output PWM signal can be turned on or off by setting the MUTE pin high or low. When the MUTE pin is low, the internal oscillator is stopped. This oscillator operates at all times that the MUTE pin is high.

(2) Power On Sequence

Applications should provide a power-on muting period of at least 500ms to minimize impulse noise.

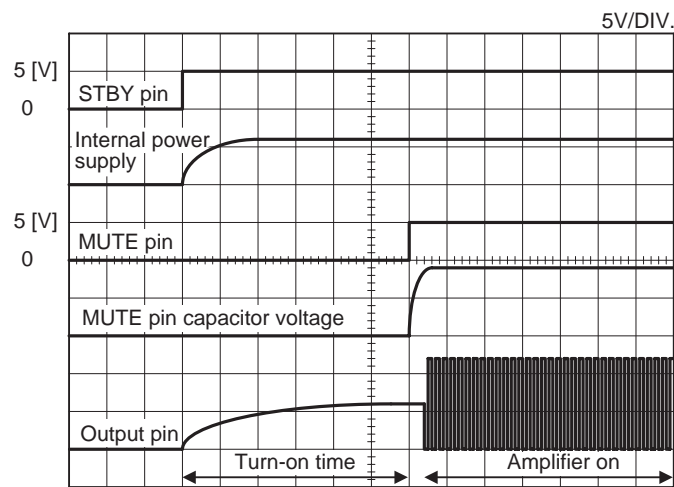

Turn-on time : the time between the point the STBY pin is set high and the point the MUTE pin is set high.

(3) Power Down Sequence

Applications should provide a power down muting period of at least 100ms to minimize impulse noise.

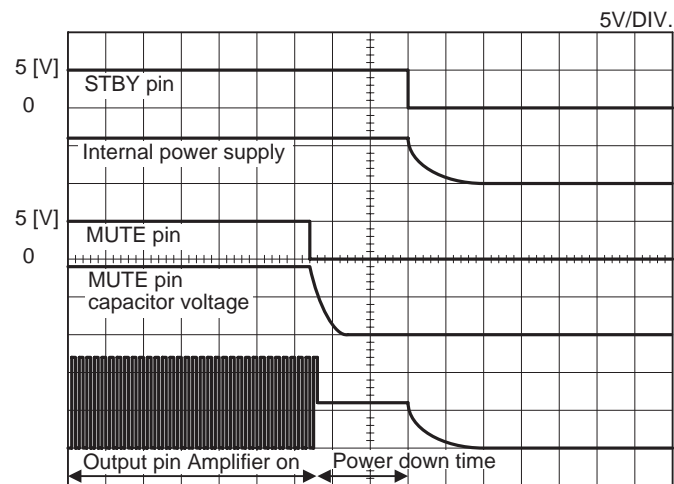

Turn-off time : the time between the point the MUTE pin is set low and the point the STBY pin is set low.

LV4900H

LV4900H customer bread board rev.2.0

Pattern

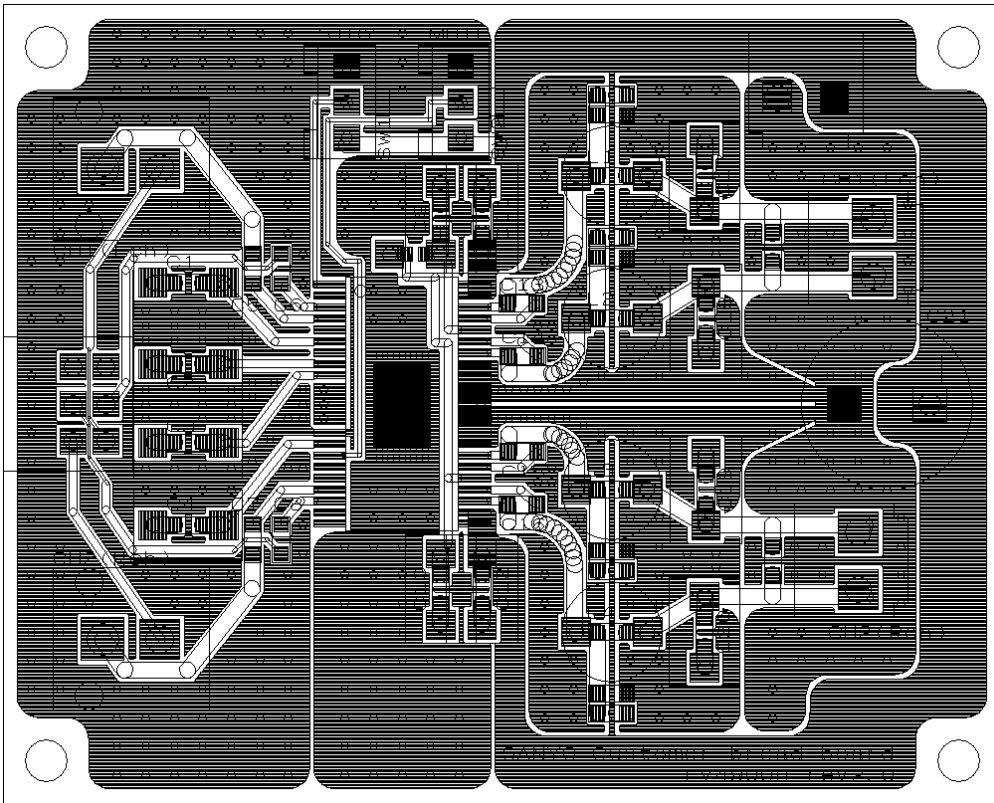

Silk

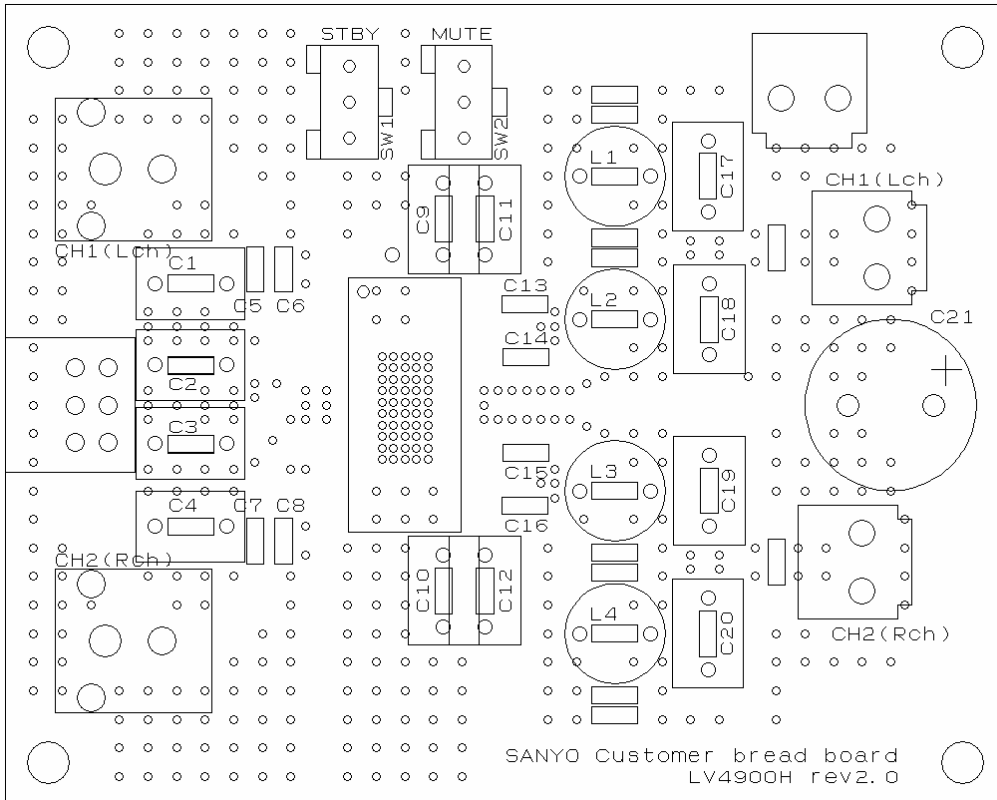

LV4900H

Components

Symbol	Part No.	Function
-----	SW1	Standby switch. Lower position: standby state
-----	SW2	Mute switch. Lower position: mute state
C _{VCC}	C1	Internal power supply (V _{CC}) output coupling capacitor
C _{BIASCAP}	C2	Internal power supply (V _{BIAS}) input coupling capacitor
C _{VBIAS}	C3	Internal power supply (V _{BIAS}) output coupling capacitor
C _{MUTE}	C4	Soft muting time constant adjustment capacitor
C _{IN}	C5, C6, C7, C8	Input capacitors
* C _{VDD}	C9, C10	Internal power supply (V _{DD}) output coupling capacitors
* C _{VD}	C11, C12	VD high-frequency attenuation capacitors
* C _{BOOT}	C13, C14, C15, C16	Bootstrap capacitor
L _O	L1, L2, L3, L4	Output low-pass filter coils: $f_c = 1 / (2\pi\sqrt{L_O C_O})$
C _O	C17, C18, C19, C20	Output low-pass filter capacitors
C _{VD}	C21	VD power supply capacitors

* C_{VDD}, C_{VD} and C_{BOOT}. Each capacitor is arranged in the neighborhood of IC as much as possible.

LV4900H

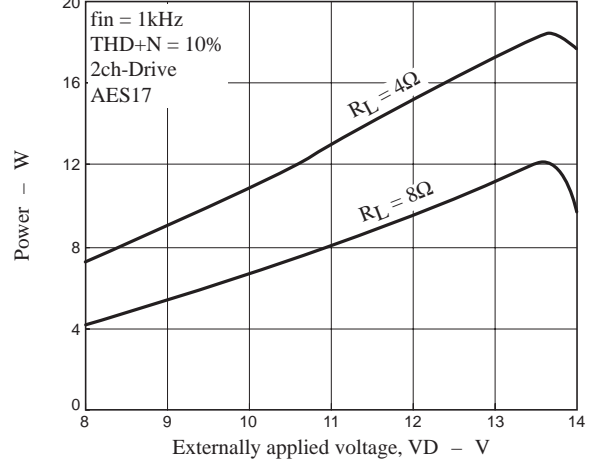
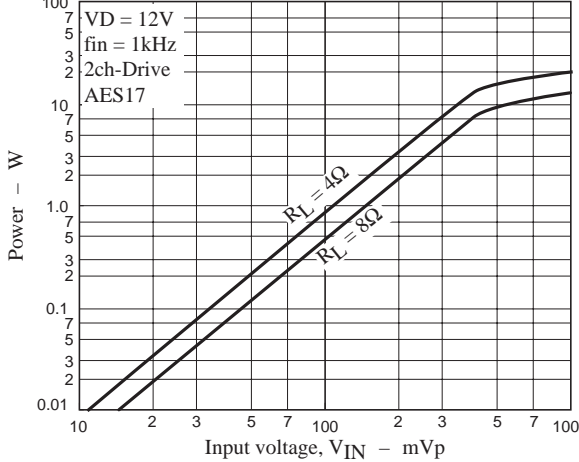
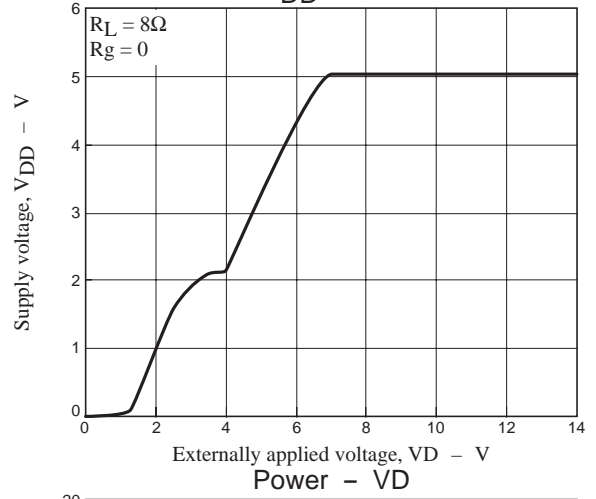
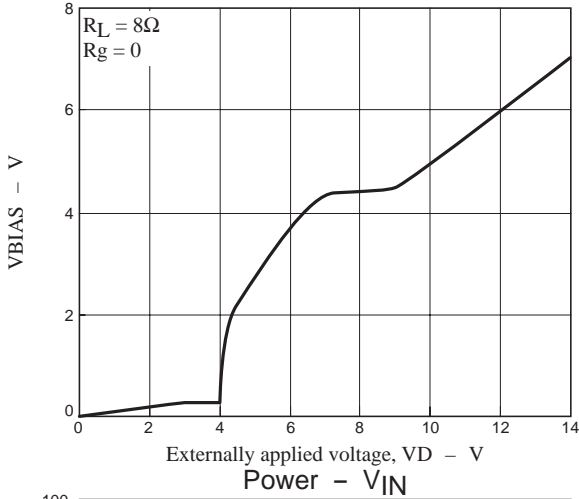
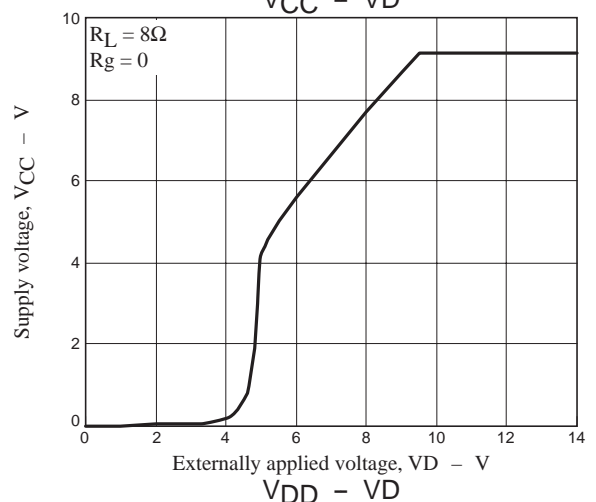
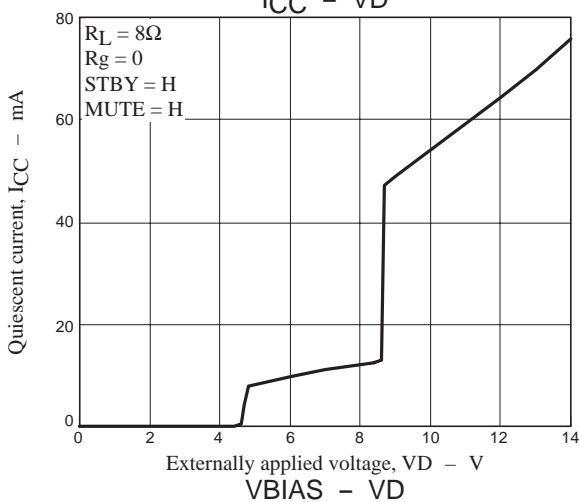
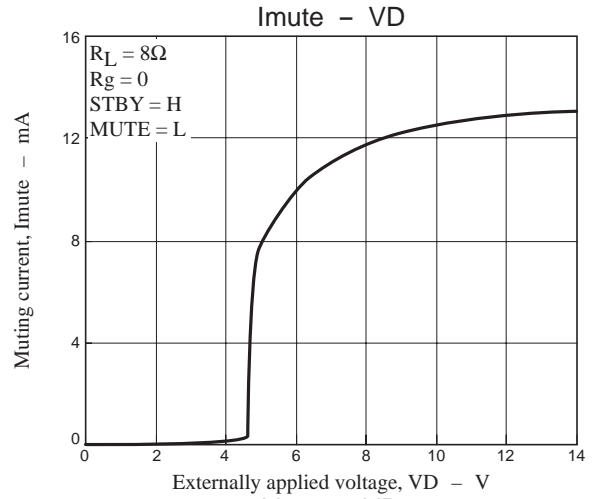
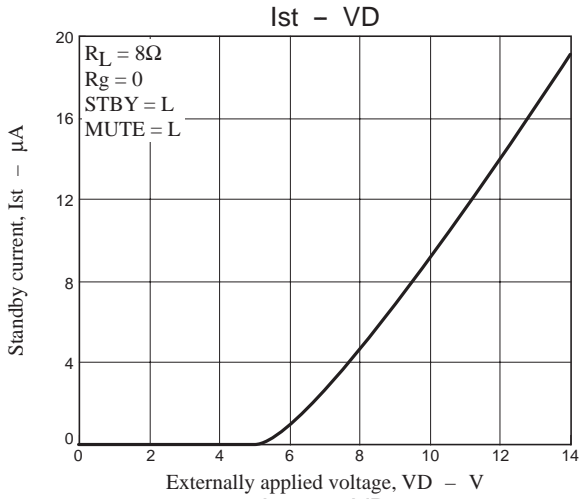

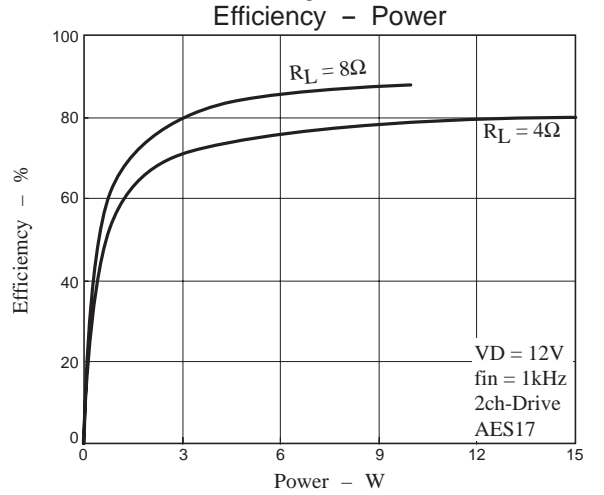
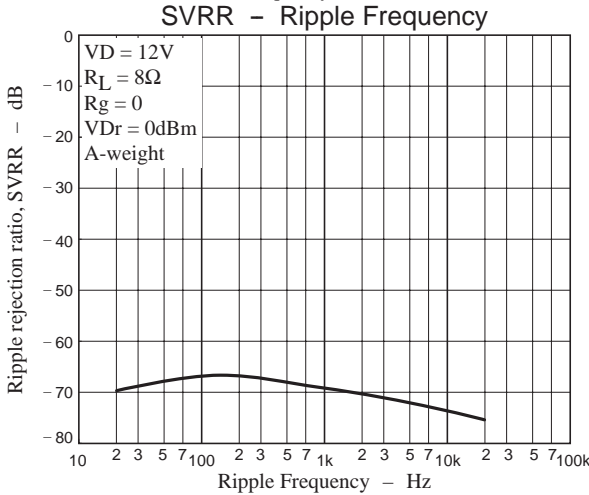
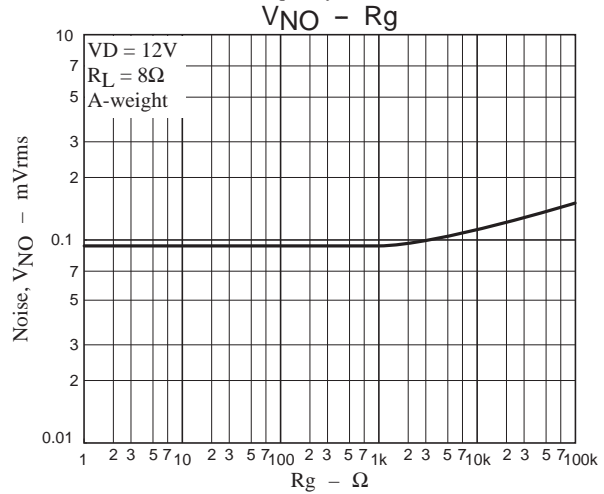
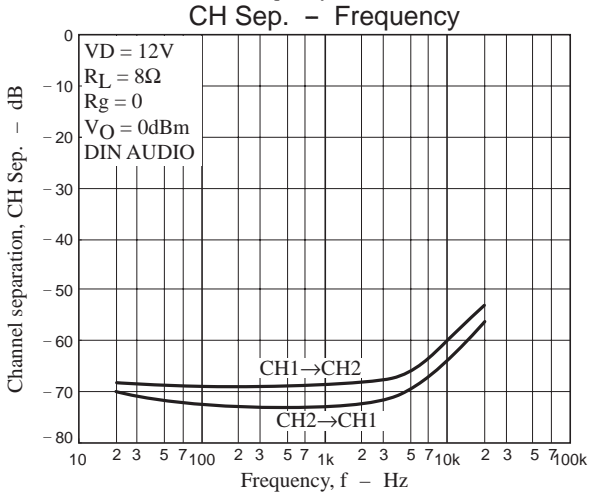
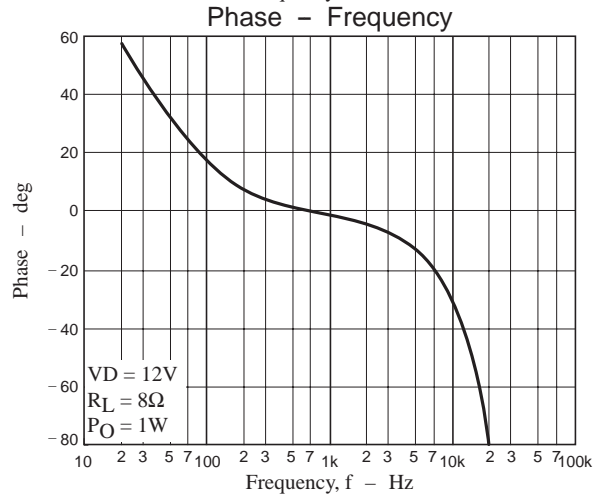
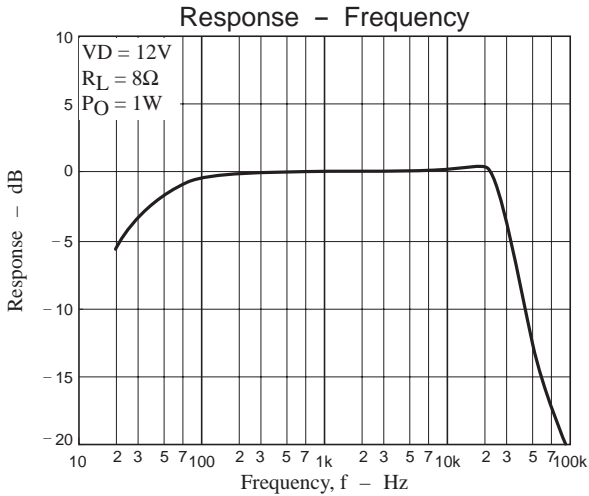
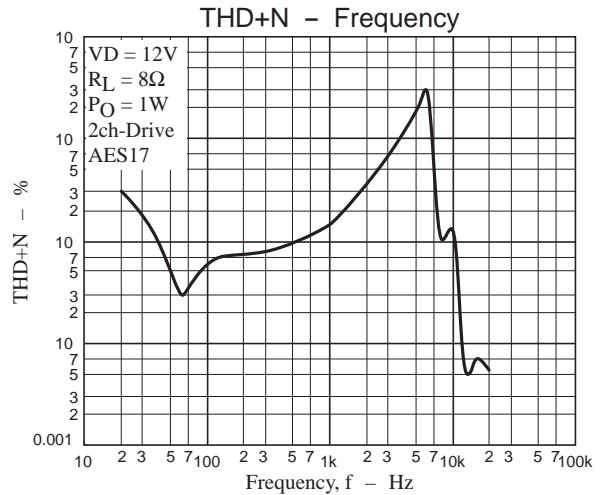
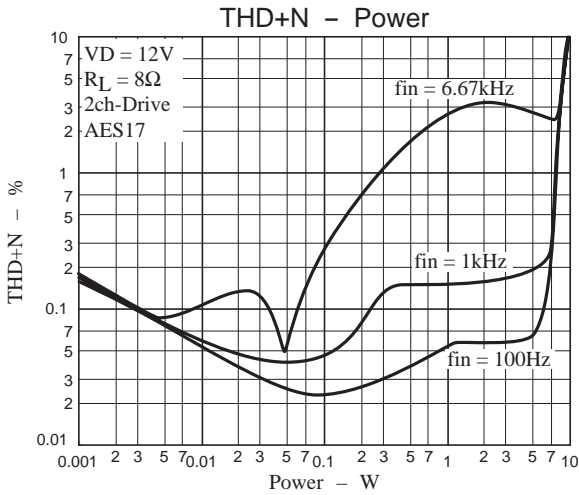

- SANYO Semiconductor Co.,Ltd. assumes no responsibility for equipment failures that result from using products at values that exceed, even momentarily, rated values (such as maximum ratings, operating condition ranges, or other parameters) listed in products specifications of any and all SANYO Semiconductor Co.,Ltd. products described or contained herein.
- SANYO Semiconductor Co.,Ltd. strives to supply high-quality high-reliability products, however, any and all semiconductor products fail or malfunction with some probability. It is possible that these probabilistic failures or malfunction could give rise to accidents or events that could endanger human lives, trouble that could give rise to smoke or fire, or accidents that could cause damage to other property. When designing equipment, adopt safety measures so that these kinds of accidents or events cannot occur. Such measures include but are not limited to protective circuits and error prevention circuits for safe design, redundant design, and structural design.
- In the event that any or all SANYO Semiconductor Co.,Ltd. products described or contained herein are controlled under any of applicable local export control laws and regulations, such products may require the export license from the authorities concerned in accordance with the above law.
- No part of this publication may be reproduced or transmitted in any form or by any means, electronic or mechanical, including photocopying and recording, or any information storage or retrieval system, or otherwise, without the prior written consent of SANYO Semiconductor Co.,Ltd.
- Any and all information described or contained herein are subject to change without notice due to product/technology improvement, etc. When designing equipment, refer to the "Delivery Specification" for the SANYO Semiconductor Co.,Ltd. product that you intend to use.
- Information (including circuit diagrams and circuit parameters) herein is for example only; it is not guaranteed for volume production.
- Upon using the technical information or products described herein, neither warranty nor license shall be granted with regard to intellectual property rights or any other rights of SANYO Semiconductor Co.,Ltd. or any third party. SANYO Semiconductor Co.,Ltd. shall not be liable for any claim or suits with regard to a third party's intellectual property rights which has resulted from the use of the technical information and products mentioned above.

This catalog provides information as of January, 2008. Specifications and information herein are subject to change without notice.