

Released on Sept. 10<sup>th</sup>, 2009

## Separately-excited Step-down Switching Regulator IC

Electrical Bicycles

Amusement

Adjustable output voltage within a wide range!

Stably outputs low voltage & high current from high input voltage!

### TN8D01A, TN5D01A

MP: from Dec. 2009

500Kpcs/Month (peak time)

Sample Price:

@800 Yen (TN8D01A)

@500 Yen (TN5D01A)



### What is switching regulator?

It is a kind of switching-method DC-DC converters that switches the input power and controls the output power by turning on and off the semiconductor switching devices such as power MOSFET. **Regulator** is a kind of circuit that functions to regulate the output voltage and current to become constant. **DC-DC converter** is a DC voltage converter that outputs different DC voltages for a certain DC input voltage.

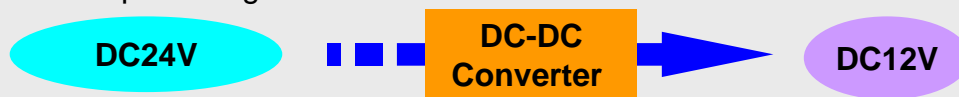

### Input Voltage & Output Current Range

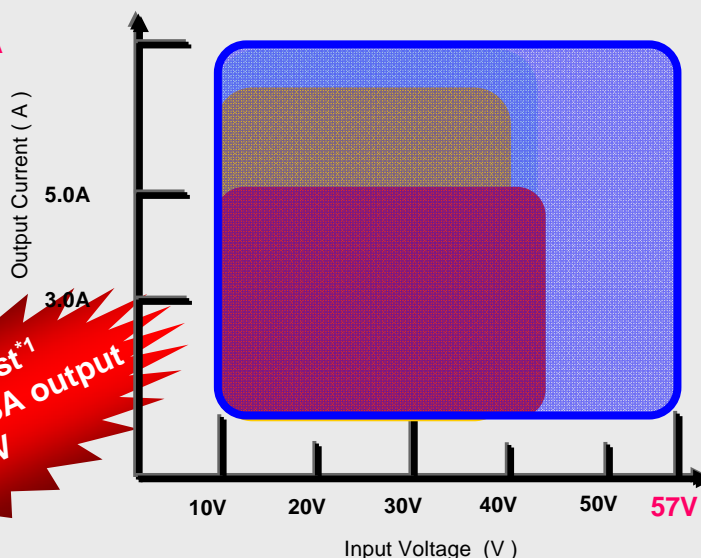

- Sanyo
- A Com.
- B Com.
- C Com.

**Achieved 2.7V output voltage!**

**The industry's first\*\*1 achievement of 2.7V/8A output from DC57V**

\*1: As of Sept. 10<sup>th</sup>, 2009, among high current of  $\geq 8A$ , TO-220 size, one package type DC-DC converters.

\*All the information in this paper, including prices and specifications, is as of July 17, 2009, and is subject to change without advance notice.

Stable Output Voltage

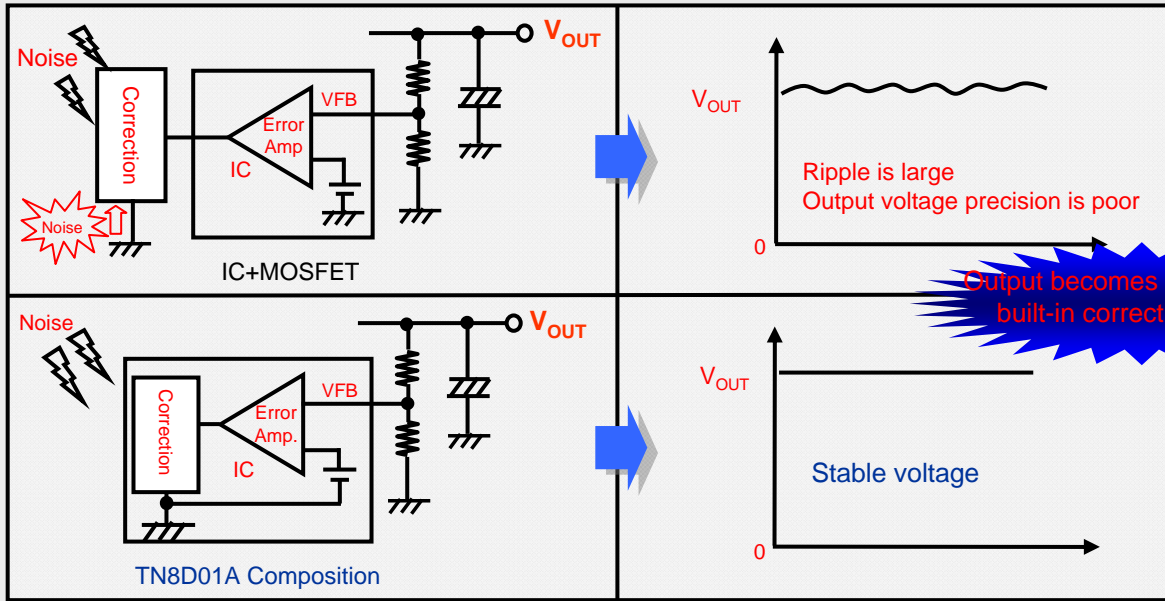

High efficiency due to variable output

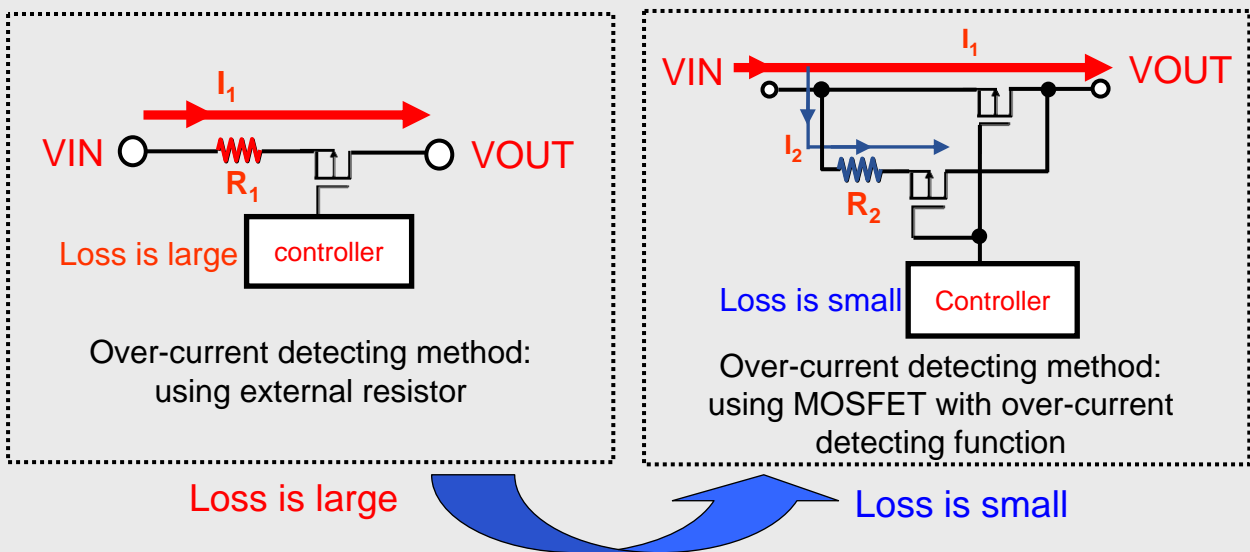

Approx. 1/5000 of  $I_1$  can be detected.

Power Supply Parts Count 50% down

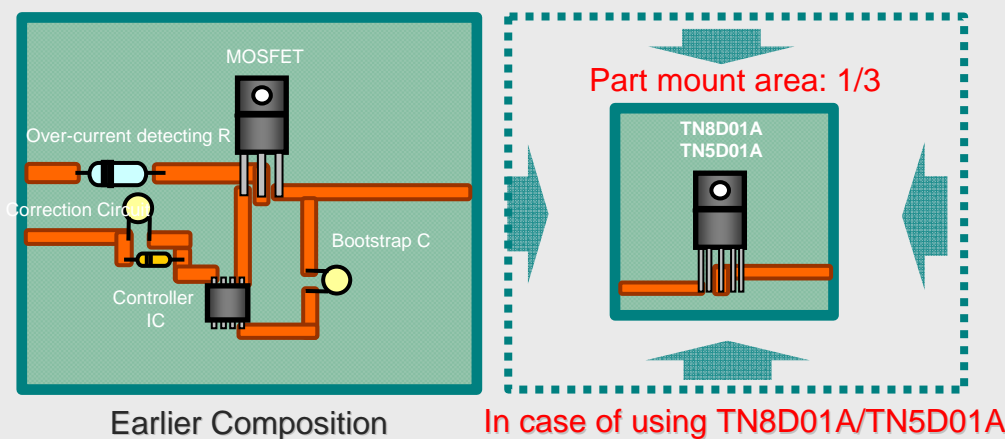

According to the adoption of peripheral parts, power supply parts count can be reduced by 50% (16→8)  
In addition, mount area reduced to 1/3!

Simplification of the circuit, reduction of the PCB area and cost!

Users' Merits (1)

Helps reduce stock & improve design flexibility!

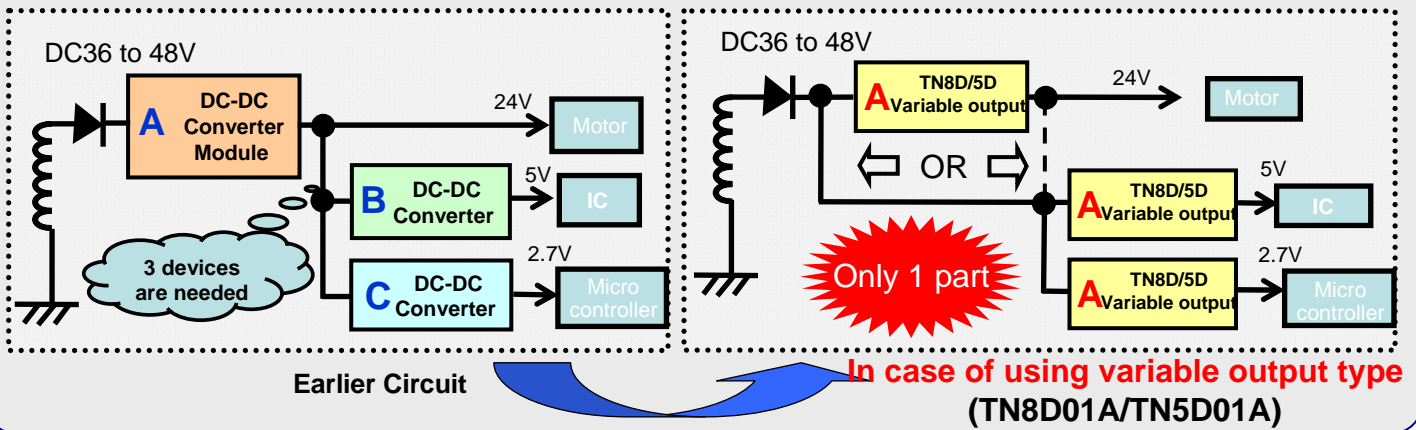

Users' Merits (2)

Output voltage can be fine-adjusted

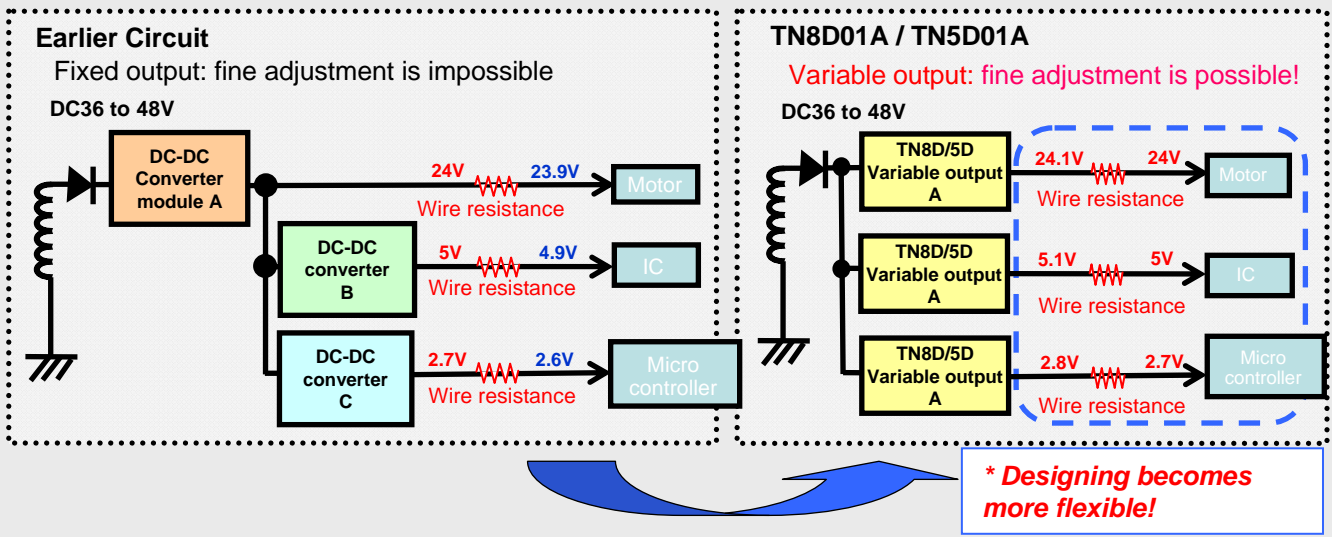

Comparison In Efficiency

Contributes to power saving of your sets!

Maker	Sanyo	A Com.	B. Com.	C Com.	
Maximum Input Voltage	57V	43V	45V	40V	
Output Current	8A	5.5A	5A	7.5A	
Efficiency	Vin=20V,Vo=5V,Io=0.5A	86%	83%	-	77%
	Vin=20V,Vo=5V,Io=1.0A	88%	-	80%	82%
	Vin=20V,Vo=12V,Io=1.0A	95%	-	91%	-
	Vin=20V,Vo=12V,Io=3.0A	95%	-	90%	-
	Vin=20V,Vo=12V,Io=8.0A	92%	-	-	-

TN8D01A: achieved high efficiency of 92% @output 8A